

VTA's BART Silicon Valley Phase II Extension Project

Santa Clara Community Working Group

May 14, 2020



Agenda

- Today's Format
- Follow-up Items
- CWG Member Report Back
- Phase I Update
- Phase II Update
- Next Steps

Quick GoToWebinar Guide

Mute/Unmute 

'Raise Hand' 

Meeting Handouts 

Ask a Question 

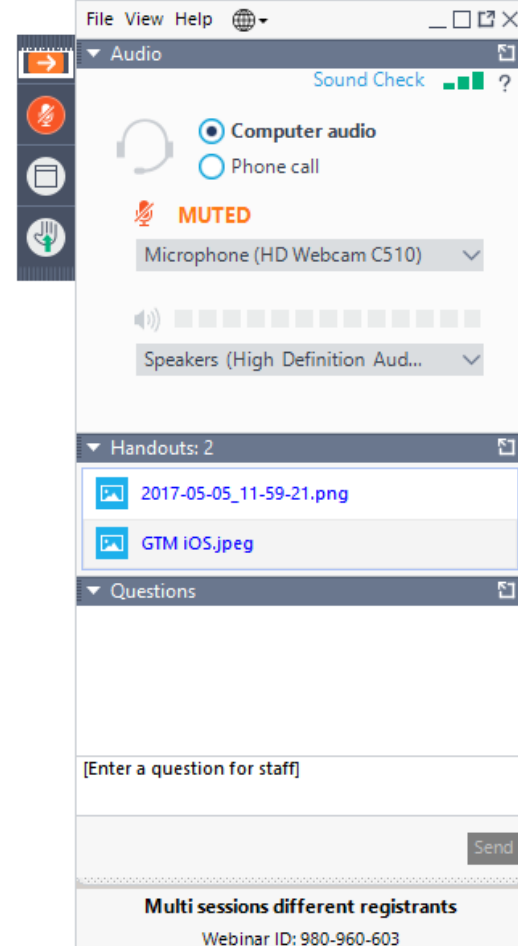

The screenshot shows the GoToWebinar interface with the following sections:

- Audio:** Includes a 'Sound Check' indicator and three icons: a microphone (muted), a document (handouts), and a hand (raise hand). Below these are radio buttons for 'Computer audio' (selected) and 'Phone call'. A 'MUTED' status is shown with a microphone icon. A dropdown menu shows 'Microphone (HD Webcam C510)'. A volume slider is present, and another dropdown shows 'Speakers (High Definition Aud...)'.
- Handouts: 2** (indicated by a dropdown arrow):
 - 2017-05-05_11-59-21.png
 - GTM iOS.jpeg
- Questions:** A text input field with the placeholder '[Enter a question for staff]' and a 'Send' button.
- Footer:** 'Multi sessions different registrants' and 'Webinar ID: 980-960-603'.



Today's Meeting Format

- Gretchen is facilitating
- Joe is managing the Go to Webinar app
- Microphones will be muted during each agenda item / presentation
- At the end of each agenda item there will be a question round. Joe will unmute members one-by-one during the question round.
 - You can also write in questions using the Questions box on the Go to Webinar app
- Please contact Gretchen after if you have any additional comments or questions.



Upcoming Meetings – Santa Clara

- **Upcoming Santa Clara CWG Dates**
 - July 2020, Date TBD
 - September 17, 2020, 4:00 – 6:00 PM
 - November 19, 2020, 4:00 – 6:00 PM
- **VTA Board of Directors vta.org/about/board-and-committees**
 - May 7, 2020, 5:30 PM
 - June 4, 2020, 5:30 PM
- **Gretchen / Kate will email alerts for other meetings, e.g. Board Workshops**



Follow-Up Items

Gretchen Baisa, VTA



Follow-up Items – Santa Clara

- Send link to BART Phase II video – ✓
- Send link to playbook once finalized - *Noted*
- Send date for Santa Clara Council Meeting TOC Workshop Presentation – ✓
- Send Downtown Precise Plan - Community Meeting information to CWG members to distribute to their networks – ✓
- Provide link to Airport RFQ responses in meeting summary – ✓



Questions



CWG Member Report Back



Report Back

- Ron Miller *Bellarmino College Preparatory*
- Curtis Leigh *Hunter Storm*
- John Urban *Newhall Neighborhood Association*
- Sudhanshu Jain *Old Quad Residents Association*
- Ana Vargas-Smith *Reclaiming Our Downtown*
- Luke De Vogelaere *San José Earthquakes*
- Nick Kaspar *Santa Clara Chamber of Commerce*
- Chris Shay *Santa Clara University*
- Eddie Truong *The Silicon Valley Organization*
- Jack Morash *South Bay Historic Railroad Society*



Phase I Update

Gretchen Baisa, VTA





Phase I Update

- Major Milestones:
 - BART started pre-revenue operations on April 20
 - Next Step: CPUC Certification
- BART Service During Shelter in Place Orders:
 - With service reduced during the shelter in place order, trains will run every 30 minutes on weekdays and every 24 minutes on weekends
- Revenue Service Date – To Be Announced

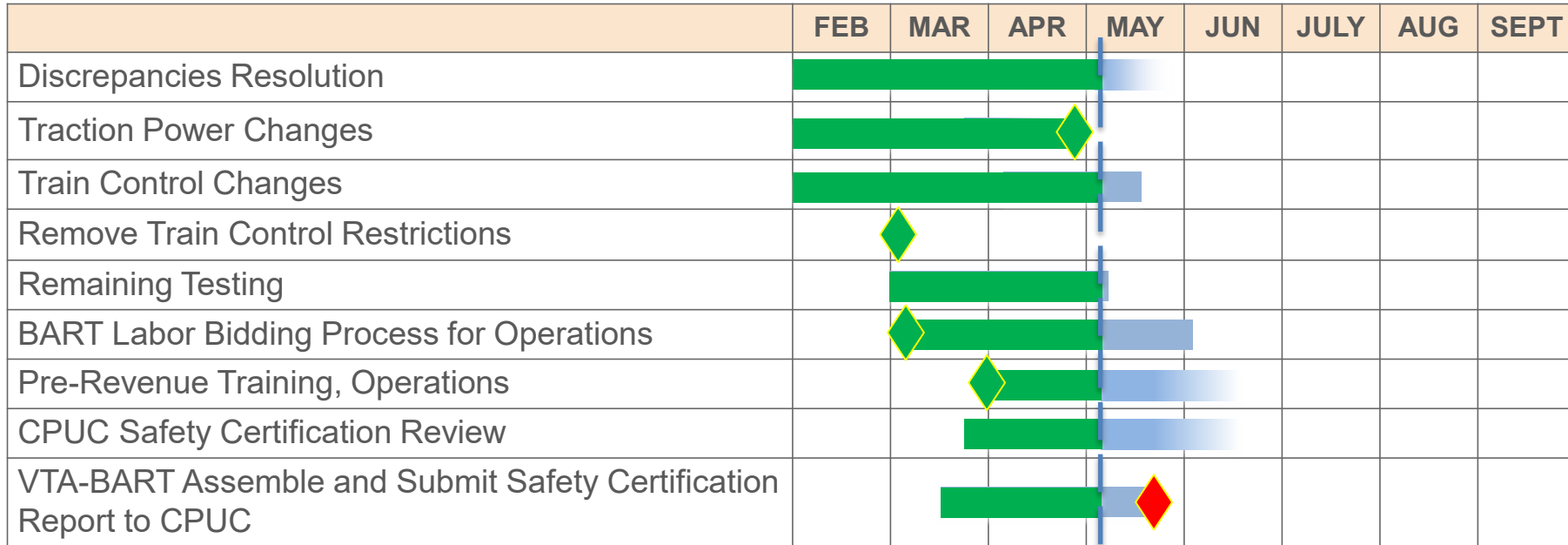

Framework to Passenger Service



- Significant progress made in System Safety Certification
- Systems Safety Certification Verification Report will be submitted 21 days prior to revenue service
- Green diamonds  represent completed milestones; red diamond  is the upcoming milestone



New BART Map

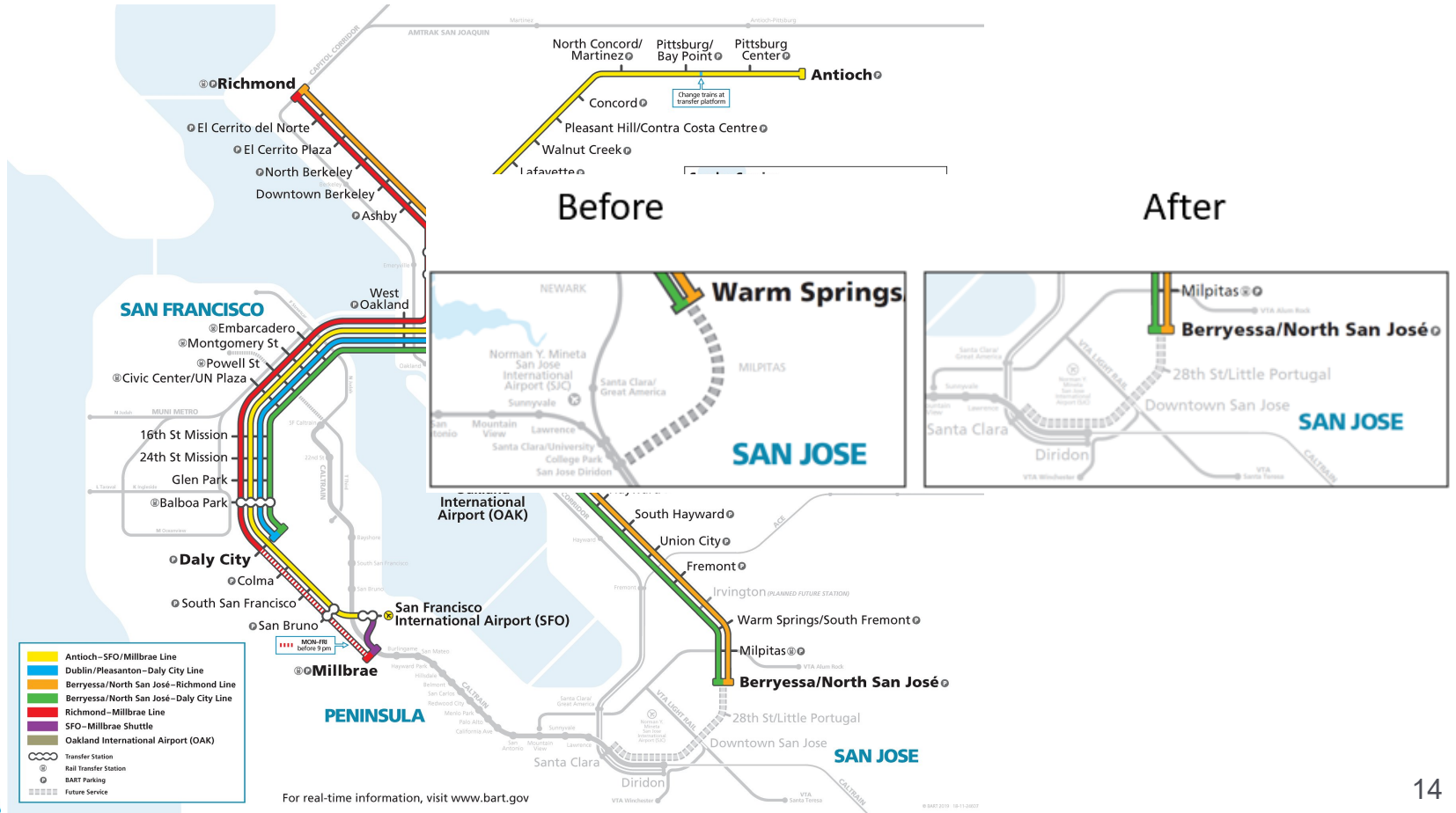

New BART Map

Before



After

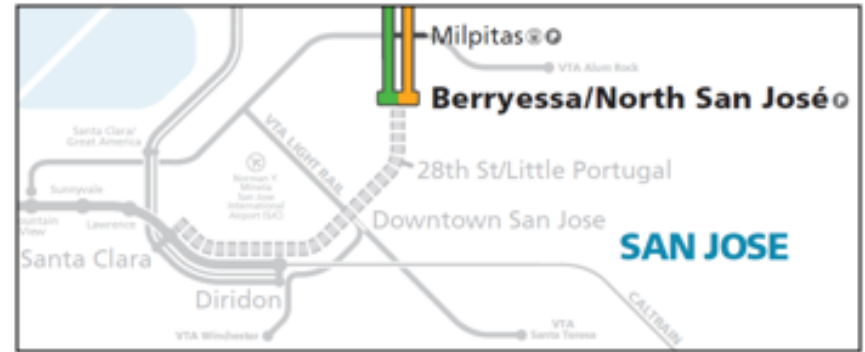

Questions

Phase II Update

Bernice Alaniz, Ronak Naik, VTA



Single-Bore with Center Platform

- Concurrent to pursuing Federal funding, VTA and BART explored a larger single-bore tunnel with side-by-side tracks and center platform
- Engineering on the larger single bore with center platform was advanced to 10% design and showed higher projected costs and risks, thus prompting consideration of alternatives

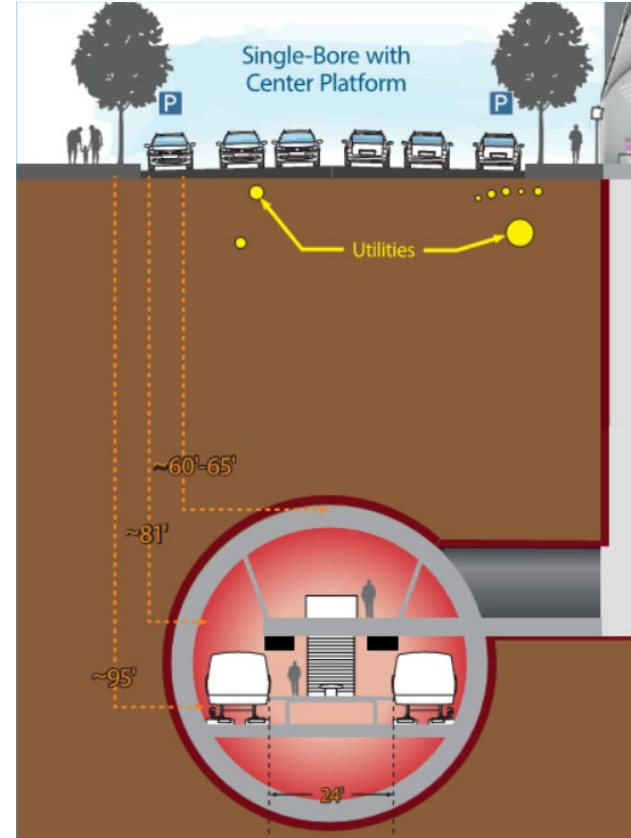

Approximately 56-foot diameter
Tunnel Boring Machine

Criteria for Evaluation of Tunnel Configurations

1. Funding constraints
2. Federal funding process
3. Environmental clearance
4. Construction impacts
5. Contracting risk
6. Innovation opportunities
7. Consistency with BART system



BART's Operational Concerns for Stacked Configuration

Emergency Egress

Enclosed stairwells in the tunnel sections as a means for emergency evacuation is not considered intuitive for passengers

Operations

Challenges with train operations due to ramps/transitions and associated emergency egress

Ventilation

Proposed designs differ from typical BART underground system and would require specialized training of employees

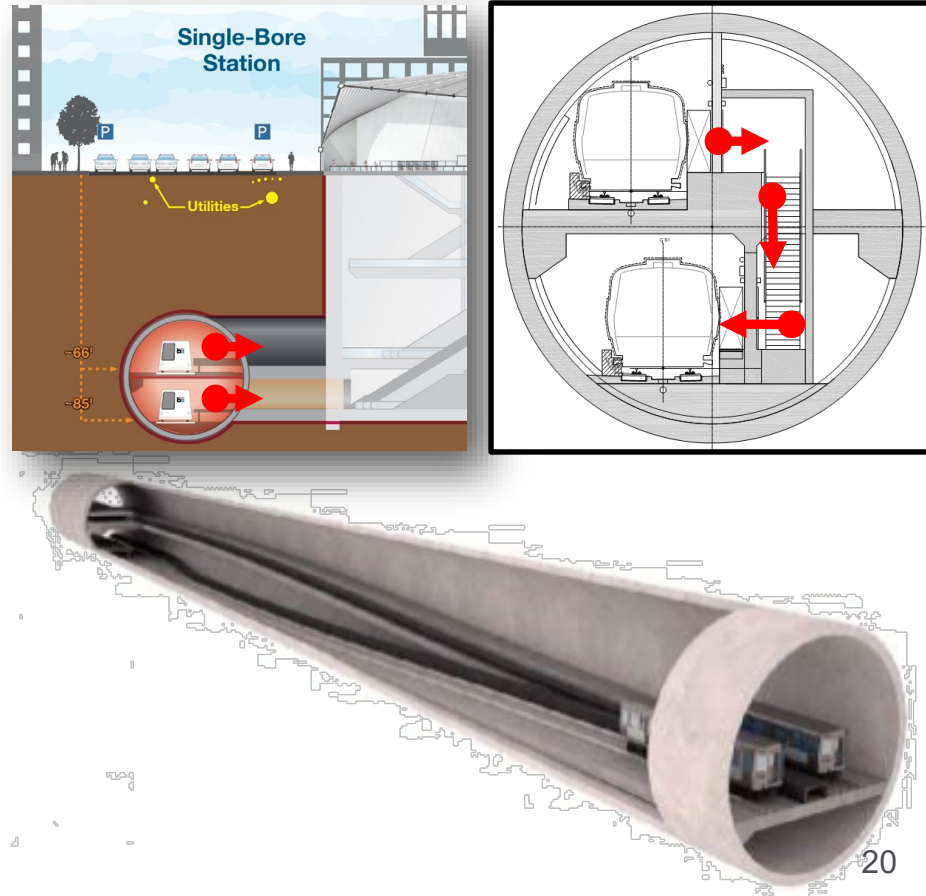

Addressing BART's Operational Concerns

- Use 13th Street and Stockton Avenue mid-tunnel facilities to optimize ventilation, emergency evacuation, and provide operational flexibility
 - Limit transitions (ramps) between stacked and side-by-side track configurations to two locations (at ventilation facilities)
 - Provide emergency evacuation platforms at ventilation facilities
 - Provide crossovers (switches) for operational flexibility



Project Alignment

LEGEND

- Phase I Alignment
- Phase II Ground-Level Alignment
- Phase II Single-Bore Tunnel Alignment
- Ventilation Facility



Summary

- Two optimized concepts presented at the April 17 Board of Directors Special Meeting
- Concepts address BART's main operational concerns for single-bore stacked configuration
- Staff reviewed both concepts through the lens of public and Board feedback including minimizing street level impacts, business/community disruptions, and pre-established criteria (cost, schedule, risks, etc.)



Optimized Single-Bore Tunnel Concept

- Provides the most opportunity to minimize street-level impacts
- Provides opportunity for further optimization
- Addresses BART's operational concerns related to emergency egress, operations, and ventilation

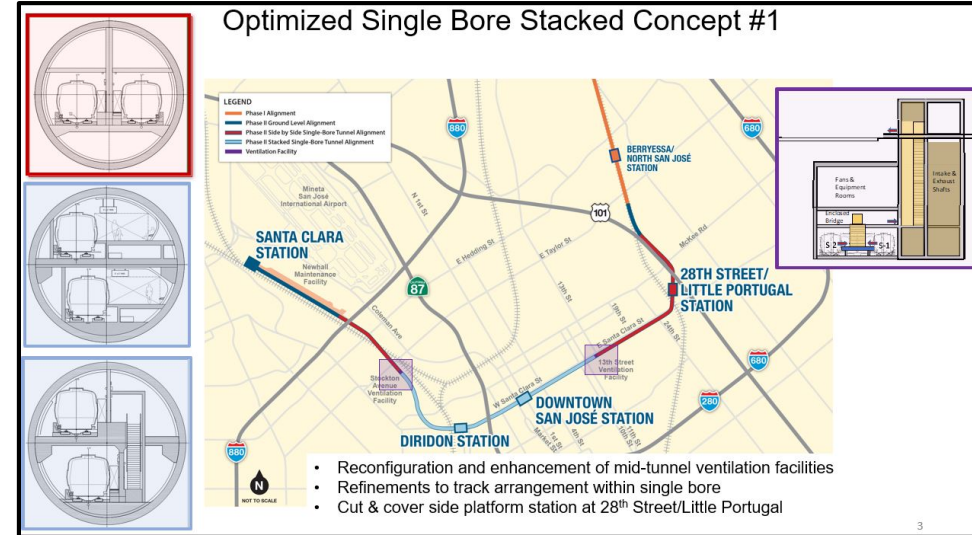

Optimized Single-Bore Tunnel Concept

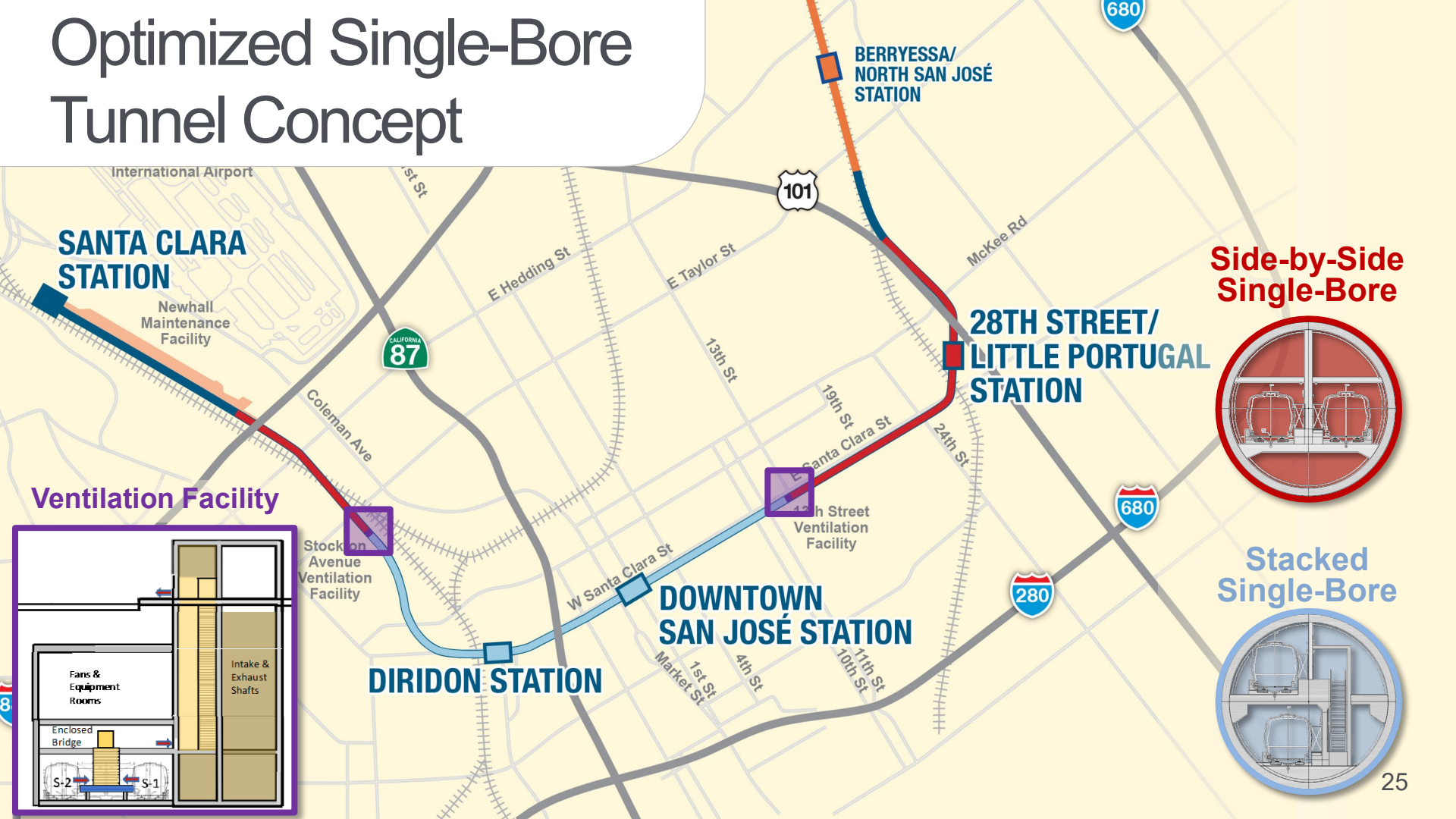

SANTA CLARA STATION

Newhall Maintenance Facility

Ventilation Facility

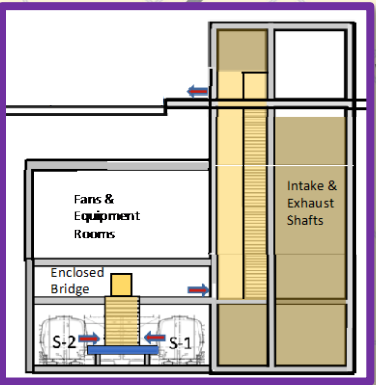

Stockton Avenue Ventilation Facility

**BERRYESSA/
NORTH SAN JOSÉ STATION**

**28TH STREET/
LITTLE PORTUGAL STATION**

Side-by-Side Single-Bore

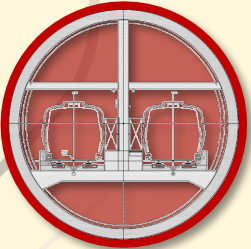

Stacked Single-Bore

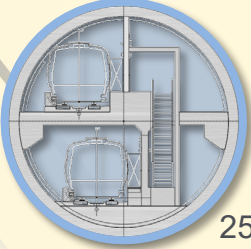

**DOWNTOWN
SAN JOSÉ STATION**

DIRIDON STATION

Optimized Single-Bore Tunnel

- Single-bore tunnel with stacked track and platform configuration through downtown segment (13th Street to Stockton Avenue)

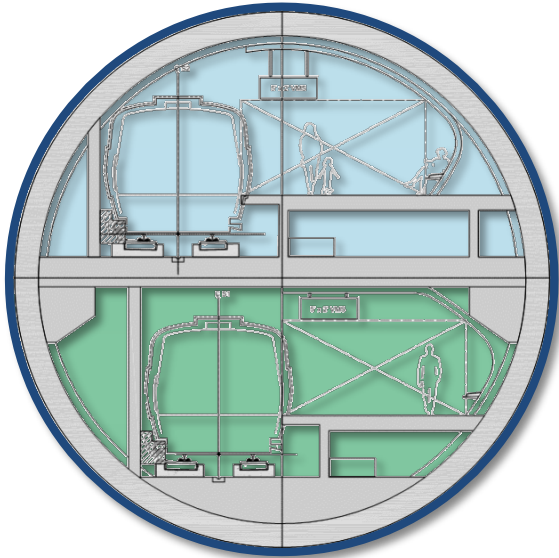

- Construction of emergency egress center platform adjacent to the ventilation facilities on either end of the Downtown/Diridon segment

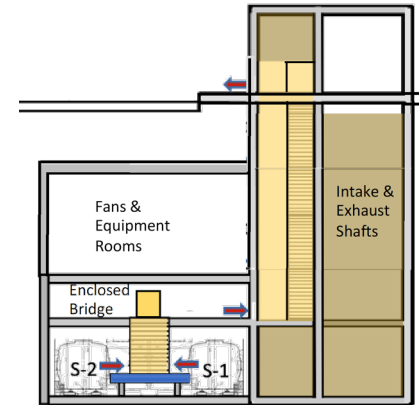

- Cut-and-cover construction of 28th Street/Little Portugal Station and emergency egress platforms at 13th Street and at Stockton Avenue facilities

Track Configuration

- One single-bore tunnel for entire 5-mile tunnel alignment
- Stacked configuration between 13th Street and Stockton Avenue Facilities
- Side-by-side running track configuration east of 13th Street and north/west of Taylor Street (along Stockton Avenue)

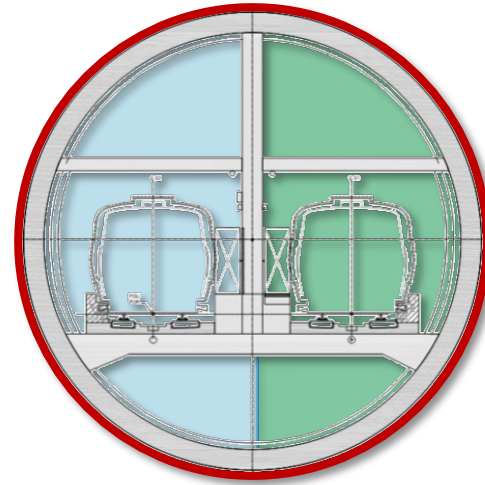
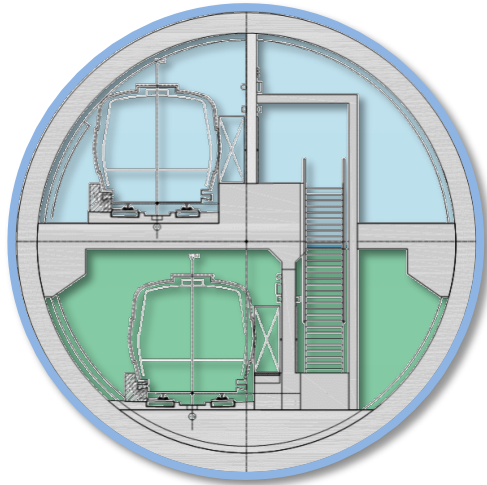

Emergency Egress/Ventilation Facilities

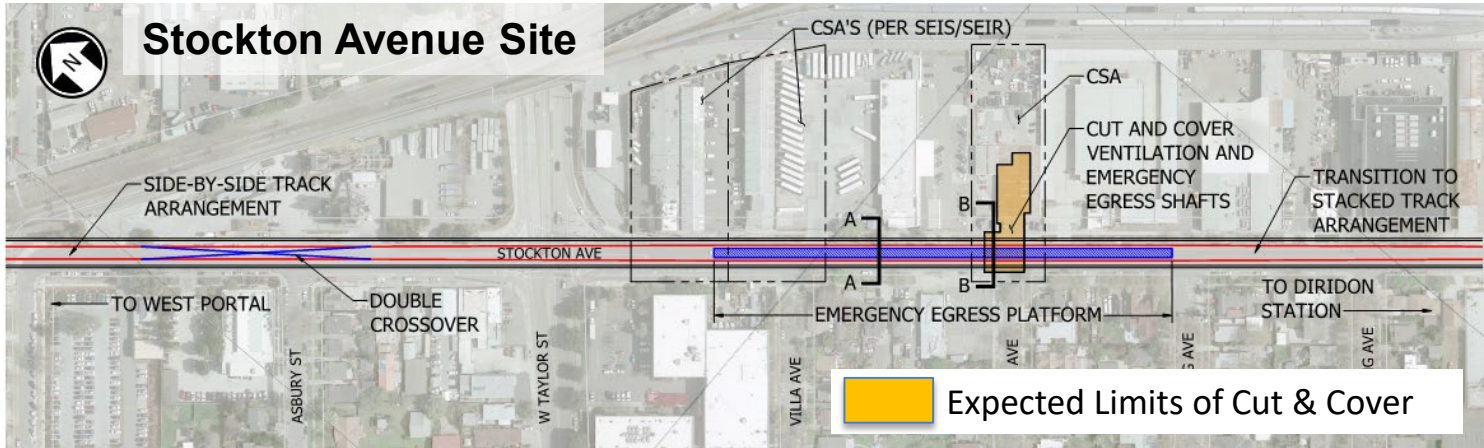
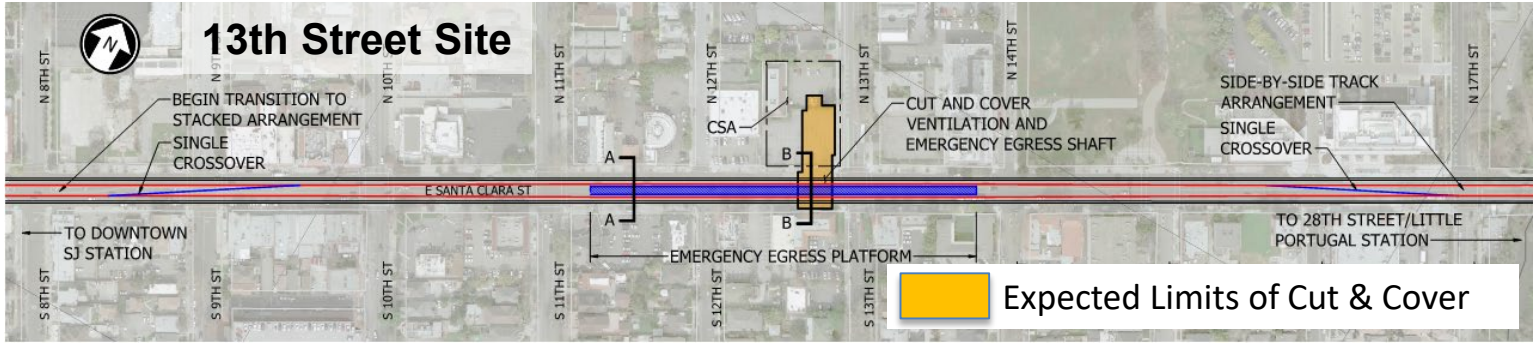

Site identified for exhibit purposes only. Final location TBD



Next Steps

- Advance design of Optimized Single-Bore concept including assessment of any potential environmental, right-of-way, and utility considerations
- Develop cost estimate, schedule, and risk register
- Prepare documents to submit for FTA's Expedited Project Delivery Pilot Program



Next Steps

- Next CWG meeting:
July (TBD), 4:00 PM, Virtual Meeting
 - CWG Member Report Backs
 - Diridon Integrated Station
Concept Plan
 - Phase II Update
 - Construction Education &
Outreach Plan
 - Related Transportation
Planning Efforts
- Action Items